

# Non-Flammable Wire Wound Fixed Resistors

## GENERAL SPECIFICATIONS

Model	Power Rating[W]	Resistance Range[Ω]	Weight[g]	Tolerance (%)
KR	80	0.02 ~ 4	40	K (±10)
	100	0.03 ~ 5	170	
KRIB	120	0.03 ~ 6	200	
	150	0.04 ~ 8	250	
KRZG	200	0.05 ~ 10	306	
	300	0.08 ~ 15	650	
	400	0.10 ~ 20	800	



## CHARACTERISTICS

Power Rating Load	[ΔR/R ≤ ±1%]	(JIS-C-5202, 5-4) 375 °C maximum
Insulation Resistance		100MΩ minimum DC 500V
Dielectric Withstanding Voltage		KR, KRIB: AC 2000V 1 minutes, KRZG: AC 3000V 1 minutes
Temp. Coefficient		±400ppm/°C maximum
Short Time Overload	[ΔR/R ≤ ±2%]	300% rated power 5 sec.
Moisture Resistance (Steady state)	[ΔR/R ≤ ±2%, 10MΩ minimum]	40°C, 95%RH, DC100V case to terminal, 500 hours
Thermal Shock	[ΔR/R ≤ ±2%]	Power rating load-30min., -55°C-15minutes
Vibration		Mount: KRZG 1.5mm 10-55Hz/1min. X,Y,Z 2 hours
Heat Resistance		375°C 2 hours
Resistors Strength		30kgf 30 sec.
Terminal Strength		10mm: 20kgf 30secs, 16mm: 20kgf 30 sec.
Flame Retardancy		100-600% rated power load
Moisture Load Life	[ΔR/R ≤ ±2%]	(10% rated power load) 90 minutes on, 30 minutes off, 40°C, 95% RH, 500 hours
Load Life	[ΔR/R ≤ ±5%]	(100% rated power load) 90 minutes on, 30 minutes off, 500 hours

## SHORT TIME OVER LOAD RATING

Load time(sec)	An overload exceeding the nominal current is allowed for a short time of 30 minutes or less.								
	5	10	30	60	180	300	600	900	1800
Max. Amps Rated Load	400%	350%	250%	200%	140%	120%	110%	105%	100%

## NEMA STANDARD/ ON-OFF CYCLING

Cycling Time (secs)	5 secs ON 75 secs OFF	10 secs ON 70 secs OFF	15 secs ON 75 secs OFF	15 secs ON 45 secs OFF	15 secs ON 30 secs OFF	15 secs ON 15 secs OFF
Max. Amps Rated Load	290%	215%	185%	160%	150%	125%

\*NEMA (National Electric Manufacturers' Association)

## CURRENT REDUCTION RATE (%) FOR GROUPED APPLICATIONS ORDERING PROCEDURE

EA	2	3	4	6	9	12	16
%	84	80	78	76	75	73	71

**KR 100**

↓

Model #

**0.102Ω**

↓

Resistance

**K**

↓

Tolerance

## DIMENSIONS [mm]

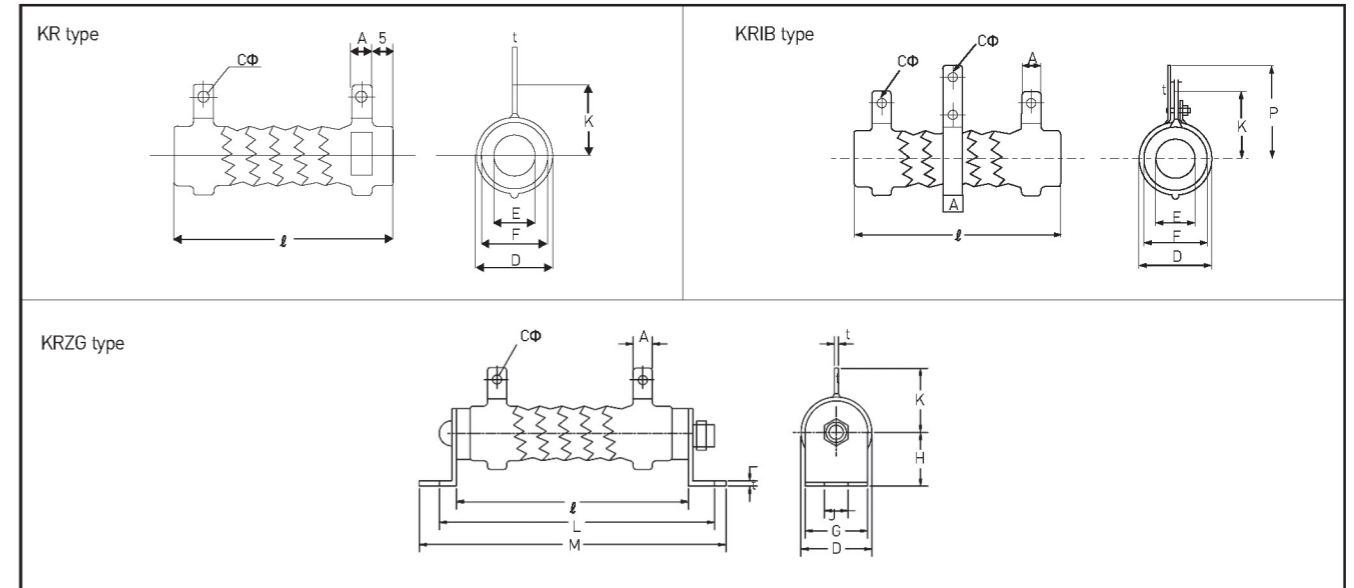

Model	Shape	Dimensions [mm] ±2													
		A	C	D	E	F	G	H	J	K	ℓ	l	M	P	t
KR	80	8	4	28	14	26	26	30	6	33	115	150	173	35	1.4
	100	8	4	28	14	26	26	30	6	33	140	175	198	35	1.4
	120	8	4	28	14	26	26	30	6	33	165	200	221	35	1.4
KRIB	150	8	4	28	14	26	26	30	6	33	195	230	253	35	1.4
	200	8	4	28	14	26	26	30	6	33	254	290	313	35	1.4
KRZG	300	12	5.5	42	24	40	40	40	6.5	45	254	300	330	52	1.6
	400	12	5.5	42	24	40	40	40	6.5	45	330	380	407	52	1.6

## DERATING CURVE AND TEMPERATURE RISE DATA

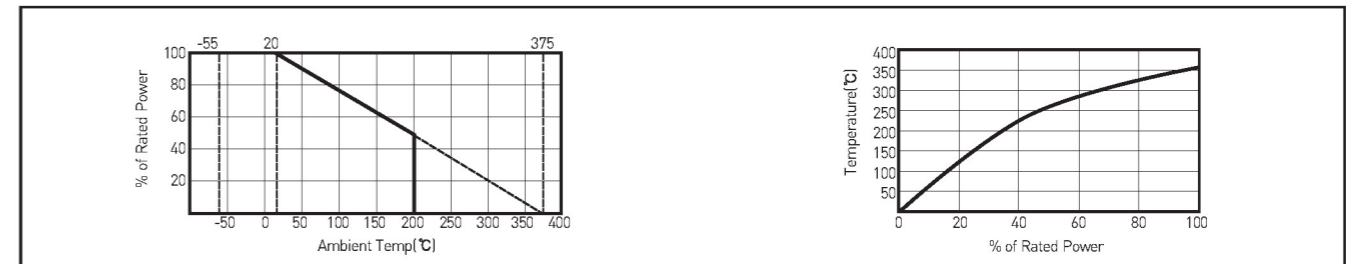

## STANDARD RESISTANCE VALUES AND MAXIMUM CURRENT

Model \ Ohm	0.02	0.03	0.04	0.05	0.06	0.08	0.1	0.15	0.2	0.25	0.3	0.4	0.5	0.6
K-80	77A	63	55	50	45	39	35	28	25	22	20	17	15	14
K-100		71A	61	55	50	43	39	32	27	25	22	19	17	16
K-120		78A	67	60	55	48	43	35	30	27	24	21	19	18
K-150			75A	67A	61	53	47	39	33	30	27	24	21	19
K-200				77A	71	61	55	45	39	35	32	27	24	22
K-300						75A	67	55	47	42	39	33	30	27
K-400							77A	63	55	49	45	39	35	31

Model \ Ohm	0.8	1.0	1.5	2.0	2.5	3.0	4.0	5.0	6.0	8.0	10.0	12.0	15.0	20.0
K-80	12A	11	9	7.8	6.9	6.3	5.5							
K-100	14A	12	10	8.6	7.8	7.1	6.1	5.5						
K-120	15A	13	11	9.5	8.5	7.8	6.7	6.0	5.5					
K-150	17A	15	12	11	9.5	8.7	7.5	6.7	6.1	5.3				
K-200	19A	17	14	12	11	10	8.6	7.7	7.1	6.1	5.5			
K-300	24A	21	17	15	13.5	12	10	9.5	8.6	7.5	6.7	6.1	5.5	
K-400	27A	24	20	17	15.5	14	12	11	10	8.7	7.7	7.0	6.3	5.5