

Non-Inductive High Power Thick Film Resistors

These are 250W, chassis mounted, non-inductive, high power resistors. The small and thin size is ideal for high density, compact instruments. These models exhibit superior vibration characteristics. The thermal resistance between the element and heat sink is excellent. Superior dielectric strength is achieved by using a 96% aluminum substrate as an insulator between the element and metal base.

Applications include: Snubber and attenuator resistors.

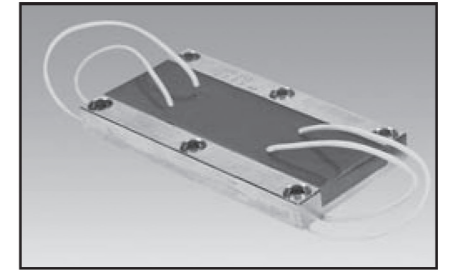

GENERAL SPECIFICATIONS

Model	Wattage Rating on Heat Sink	Resistance Range[Ω]	Tolerance(%)	Weight
HPF250	250W(see note)	5 ~ 1K	K [±10]	312g

*Note: The base of this resistor should be kept below 100 °C.

CHARACTERISTICS

Values in [] mean change in Ω after test

Temperature Range		-55 °C~+125 °C
Insulation Resistance		Over 1GΩ between two terminals and tab
Dielectric Withstanding Voltage		DC 5000V 1minute
Temp. Coefficient		±250ppm/°C
Moisture Resistance	±[2.00%+0.05Ω]	60 °C, 90 to 95%RH, DC 1W, 1000hours
Vibration	±[0.5%+0.5Ω]	JIS-C-5202
Load Life	±[2.00%+0.05Ω]	25 °C, Power rating 1.5hours on, 30minutes off, 1,000 hours
Thermal Resistance		0.1 °C/W From resistor surface to fin
Mounting Torque		15kgfcm
Max. Applied Voltage		1000V is in accordance with $E = \sqrt{P \cdot R}$
Temperature Cycle	±[0.5%+0.05Ω]	-55 °C, 30minutes, +120 °C 30minutes, 20cycles

* Note: Applied voltage: AC RMS voltage

DIMENSIONS(mm)

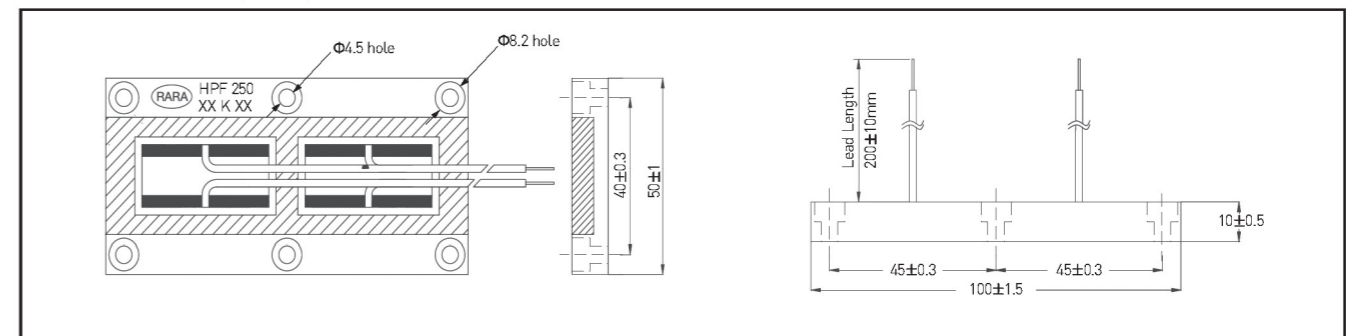

ORDERING PROCEDURE EXAMPLE

