

LR 2725

Metal Alloy Low-Resistance Resistor



■ Features

- Ideal for all types of current sensing, voltage division and Pulse applications including switching and linear power Supplies, Instruments, power amplifiers.
- Proprietary processing technique produces extremely low Resistance values.
- High-temperature performance (up to +170°C)
- Metal Strip resistive material stable and ultra low TCR. Low and Stable $TCR \leq \pm 50 \text{ppm}/^\circ\text{C}$
- Pure tin plating provides compatibility with lead (Pb) free and lead containing soldering processes.
- Compatible with "Restriction of the use of Hazardous Substances" (RoHS) directive 2002/95/EC (issue 2004).
- PFOS, PFOA, PAHs, Halogen free and REACH compliant.
- Excellent stability ($|\Delta R/R| \leq \pm 1.0\%$ for 1,000 h at 70°C) different environment conditions.
- High volume product suitable for commercial and special applications.
- Suitable for high precision current sensing circuit protection application.
- Miniature size suitable for compact Print Circuit Boards of high-precision electronic products.



■ Applications

- Power Supply, Battery Pack, DIY Tools, Inverter/Converter(AC/DC, DC/DC, DC/AC)
- Measurable Instrument, Consumer Electrics, Note Book, PC Power Pack, LED Driver
- Others (Auto Tronics...etc.).

■ GENERAL SPECIFICATIONS

Model	Power Rating at 70°C [Watts]	Max. Rating Current	Max. Overload Current	Operating Temp. Range	TCR [PPM/°C]	Resistance Range[mΩ]**	
						±0.5%(D)	±1.0%(F) ±2.0%(G) ±5.0%(J)
LR2725	4W	126.49A	252.95A	-55 ~ +170°C	0.25~0.9m=±50 1.0~3.0=±25	--	0.25~3.0

Remark :

- The Max. Power Rating is operated at 70°C.
- **Special tolerance and range of resistance are under requested.
- Rating Current : $I = \sqrt{P/R}$

■ DERATING CURVE

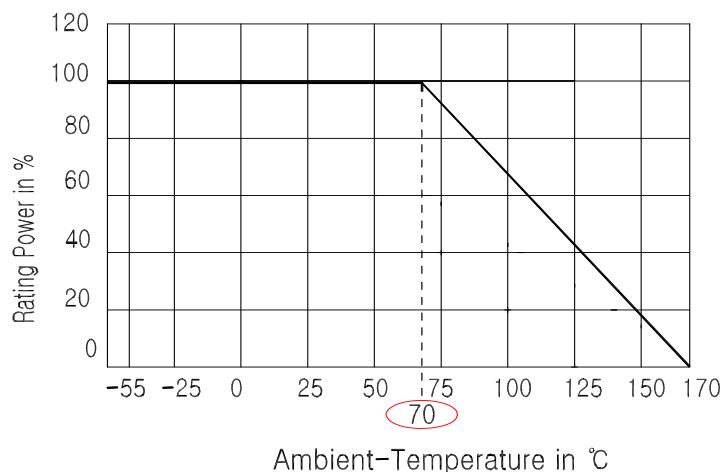

■ MARKING

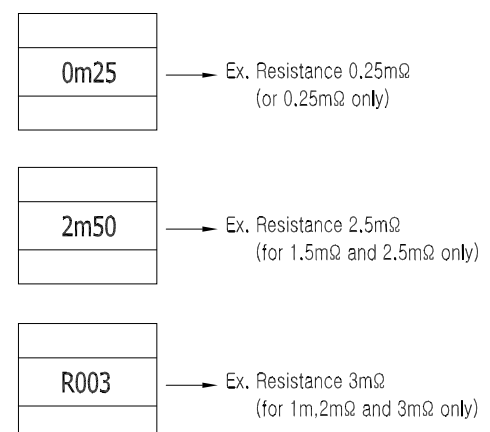

■ SOLDER PAD DIMENSIONS

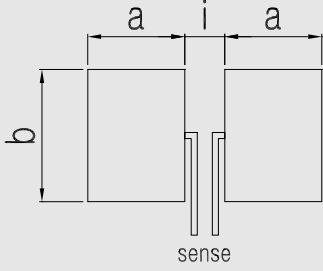
	Model	SOLDER PAD Dimension - in inches (millimetres)		
		Resistance Range [mΩ]	a	b
	LR2725	0.25~3.0	0.125(3.18)	0.270(6.86)
Remark : 4.0 Watts with total solder pad trace size of 400mm ²				

■ DIMENSIONS

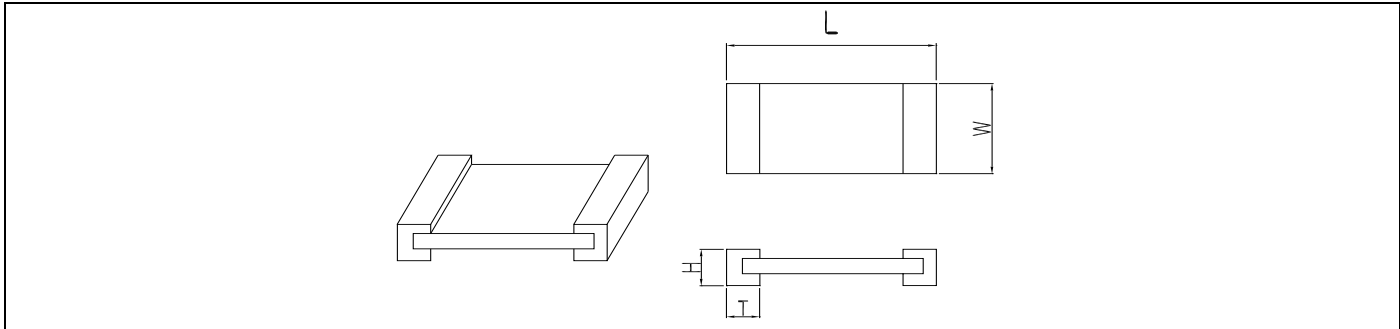

Model	DIMENSIONS - in inches (millimetres)					
	Resistance Range[mΩ]	L	W	H	T	
LR2725	0.25, 0.50	0.268±0.010 (6.807±0.254)	0.254±0.010 (6.452±0.254)	0.039±0.010 (0.991±0.254)	0.085±0.010 (2.159±0.254)	
	1.0			0.043±0.010 (1.092±0.254)		
	1.5			0.039±0.010 (0.991±0.254)		
	2.0			0.035±0.010 (0.889±0.254)	0.071±0.010 (1.803±0.254)	
	2.5					0.065±0.010 (1.651±0.254)
	3.0					0.051±0.010 (1.295±0.254)

■ CHARACTERISTICS

Short Time Overload	(R/R1) ≤ ±0.5%	4times rated power, 5sec.
Insulation Resistance	≥10 ⁹ Ω	DC100±15V fir 1minute
Dielectric Withstanding Voltage	Without break down	AC500V for 1minute, Max.50mA
Resistance to Solder Heat	(R/R1) ≤ ±0.5%	Solder temp./immersion time : 260±5℃, 10±1sec. and 350±10℃, 3.5±0.5 sec.
Solderability test	95% coverage	Specimen prep. : 4hours ±15 min. Steam Aging : Solder Bath/Dip and Look Test, 245±5℃, 3±1sec.
Vibration	(R/R1) ≤ ±0.5%	Frequency varied 55Hz in one minute,3 orientations, Total duration 12hours
Resistance to solvent	(R/R1) ≤ ±0.5%	Immersion time : 60±5sec, 20℃~25℃
Mechanical Shock	(R/R1) ≤ ±0.5%	100 grams for 6 milliseconds, 5 pulses
Low Temperature Exposure(Storage)	(R/R1) ≤ ±0.5%	1,000hours, -55℃
High Temperature Exposure(Storage)	(R/R1) ≤ ±1.0%	1,000hours, +170℃
Temperature Cycling (Rapid Temp. Change)	(R/R1) ≤ ±0.5%	Air to air, -55℃ to +150℃, 1,000cycles, 15minutes at each extreme, transition time 2 to 3 minutes
Moisture Resistance (Climatic Sequence)	(R/R1) ≤ ±0.5%	Mil-STD-202, Method 106 0% power, 7a and 7b not required, t=24 h/cycle, 10cycles, Unpowered
Bias Humidity	(R/R1) ≤ ±0.5%	+85℃,85% RH, 10% Bias, Extended Life 1000 hours, 1.5 hours On, 0.5 hours Off
Load Life	(R/R1) ≤ ±1.0%	Rated continuous working voltage : 70℃ 1000hours, 1.5hours ON, 0.5hours Off

ORDERING PROCEDURE EXAMPLE

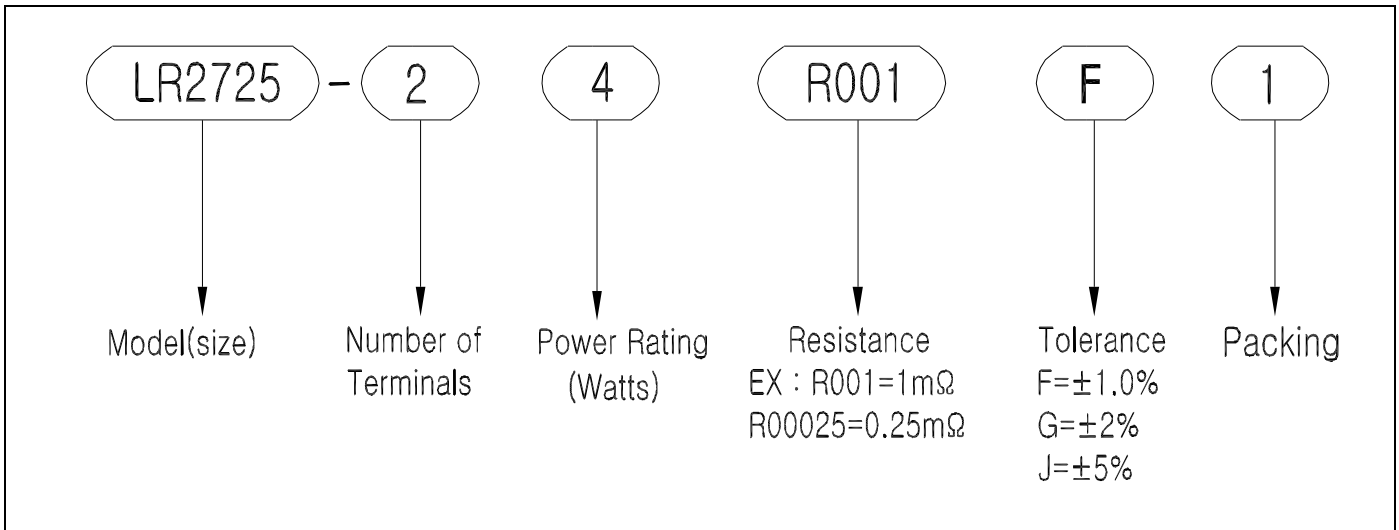

Remark

- a. "*" normal product order information has 4digits,
 if includes one decimal point then the order information should be 5 digits(e.g. 0.5mΩis R0005),
 if includes 2 decimal points, then it should be 6digits (e.g. 0.25mΩ is R00025).
- b. The detail marking format please refer to "MARKING"
- c. "***" special tolerance and range of resistance are under requested.
- d. "***" the packing quantity : 1 means 1k pieces per reel.

PACKAGING

•Embossed Dimensions

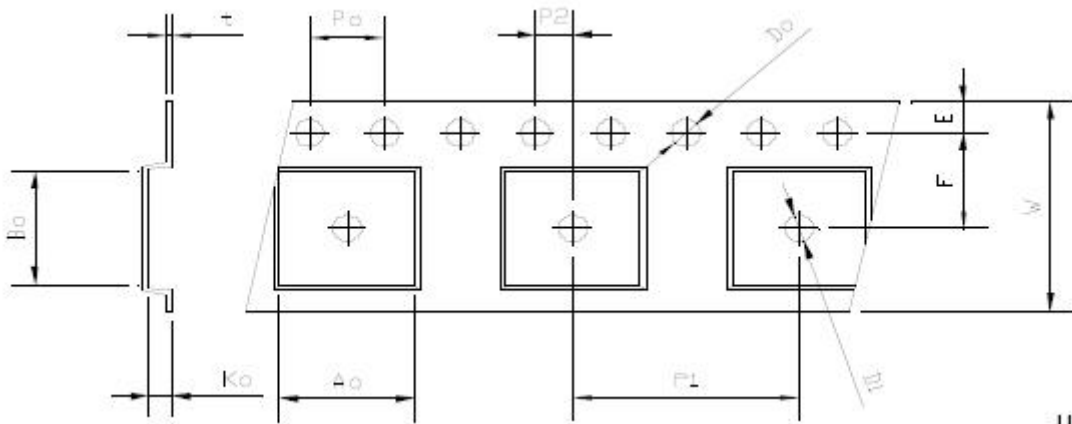

Unit: mm

Item	W	P1	E	F	Do	D1	P0	Po*10	P2	Ao	Bo	Ko	t
Spec.	12.00	8.00	1.75	5.50	1.50	1.50	4.00	40.00	2.00	6.75	7.15	1.70	0.25
Tole.	±0.15	±0.10	±0.10	±0.10	±0.05	±0.10	±0.10	±0.20	±0.10	±0.10	±0.10	±0.10	±0.05

• Reel Dimensions (Unit : mm)

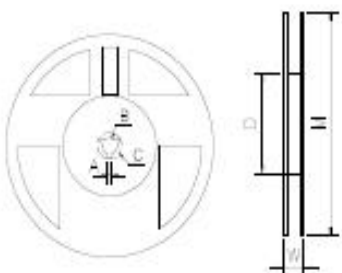

Reel Type / Tape	W	M	A	B	C	D
7" reel for 12mm embossed	16.2±0.5	178±1.0	2.5±0.5	13.5±0.5	17.7±0.5	60.0±0.5