

Power Metering Precision Shunts

These components have E-Beam welded manganese-copper alloy elements giving high strength, stability and reliability. Low thermal EMF and TCR. Small size and minimal power loss. Minimal heat generation and surface temperature due to small total resistance. Proprietary processing technique allows very low resistance values. Ideally suited for KWh meters and sampling sensor shunts. These units are also suitable for custom design.



GENERAL SPECIFICATIONS

Model	Power Rating[W]	Resistance Range[Ω]	Tolerance(%)
PMS	3	100μΩ~1200μΩ	F [±1], J [±5], K [±10]

CHARACTERISTICS

Temperature Range	-55°C~+125°C
Temp. Coefficient	≤±50ppm/°C
Internal Heat Resistance	< 10K/W
Load Life	Deviation < 0.5% after 2000 hours at 70 °C

DIMENSIONS [mm]

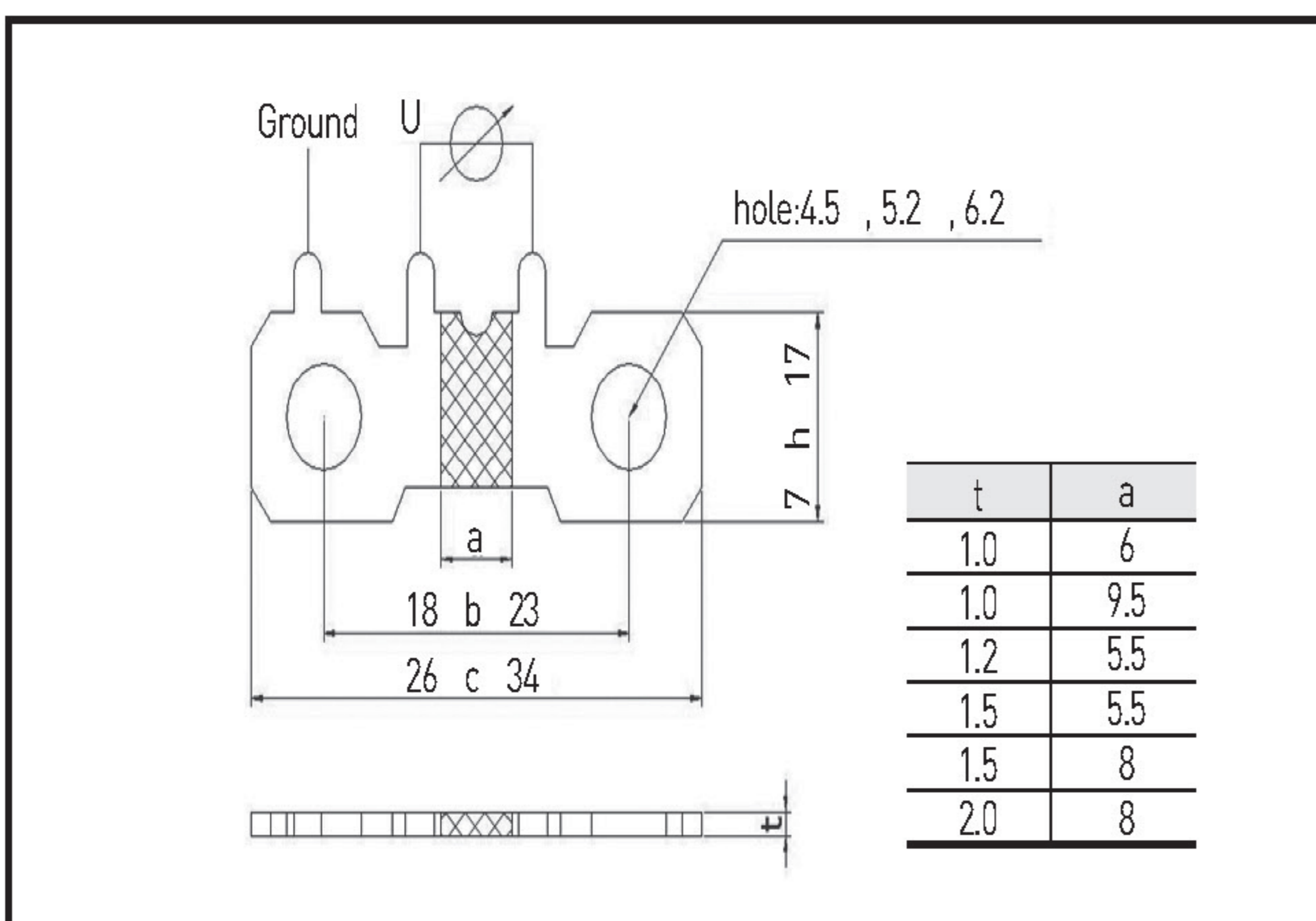

DERATING CURVE

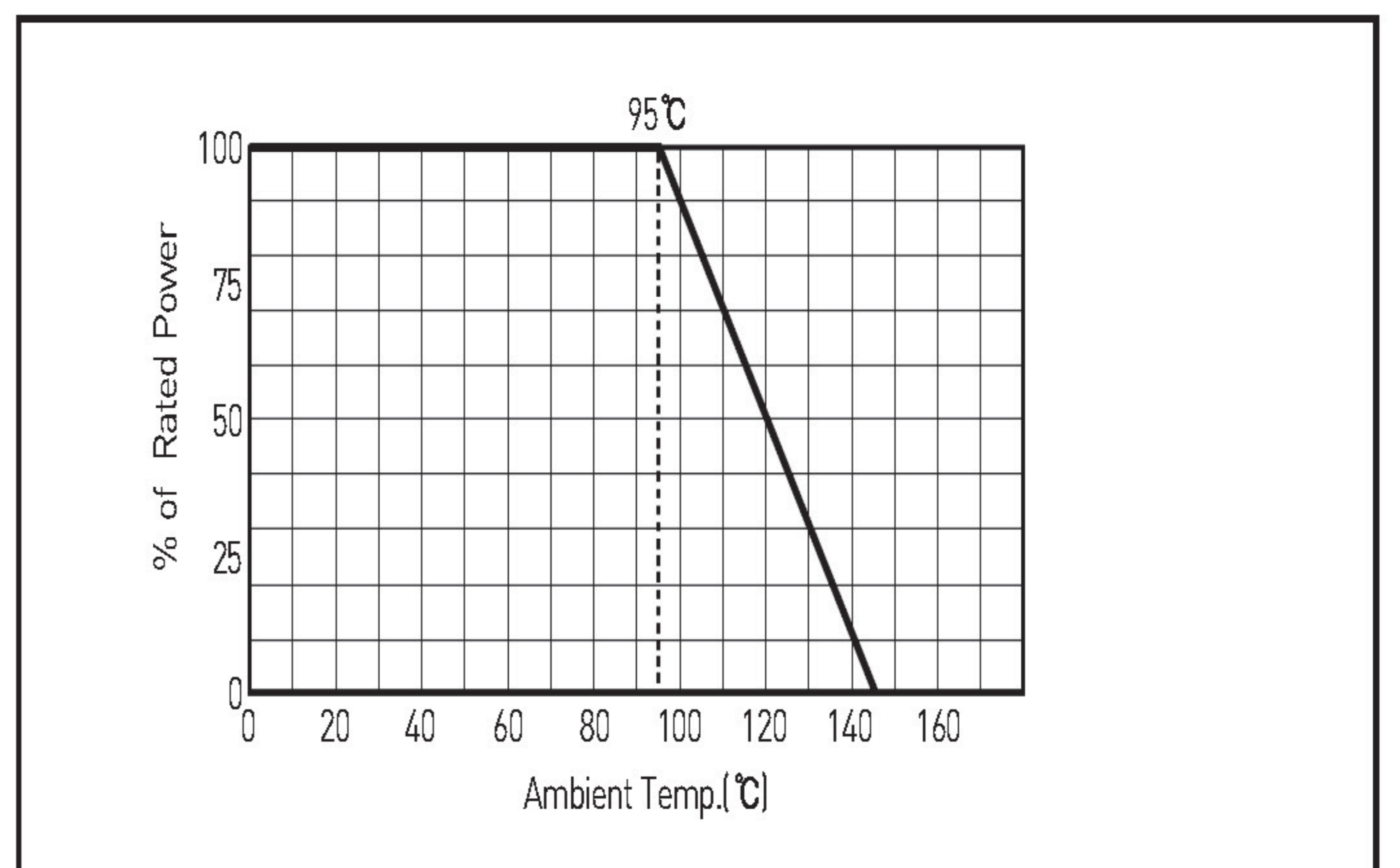

Resistance Value	Thickness	Rated Current
≤100μΩ	2.0mm	100A
120μΩ	1.5mm	80A
150μΩ	1.5mm	60A
200μΩ	1.2mm	60A
250μΩ	1.2mm	40A
300μΩ	1.0mm	40A
350μΩ	1.0mm	30A
500μΩ	1.0mm	25A
1200μΩ	1.0mm	15A

ORDERING PROCEDURE EXAMPLE

