

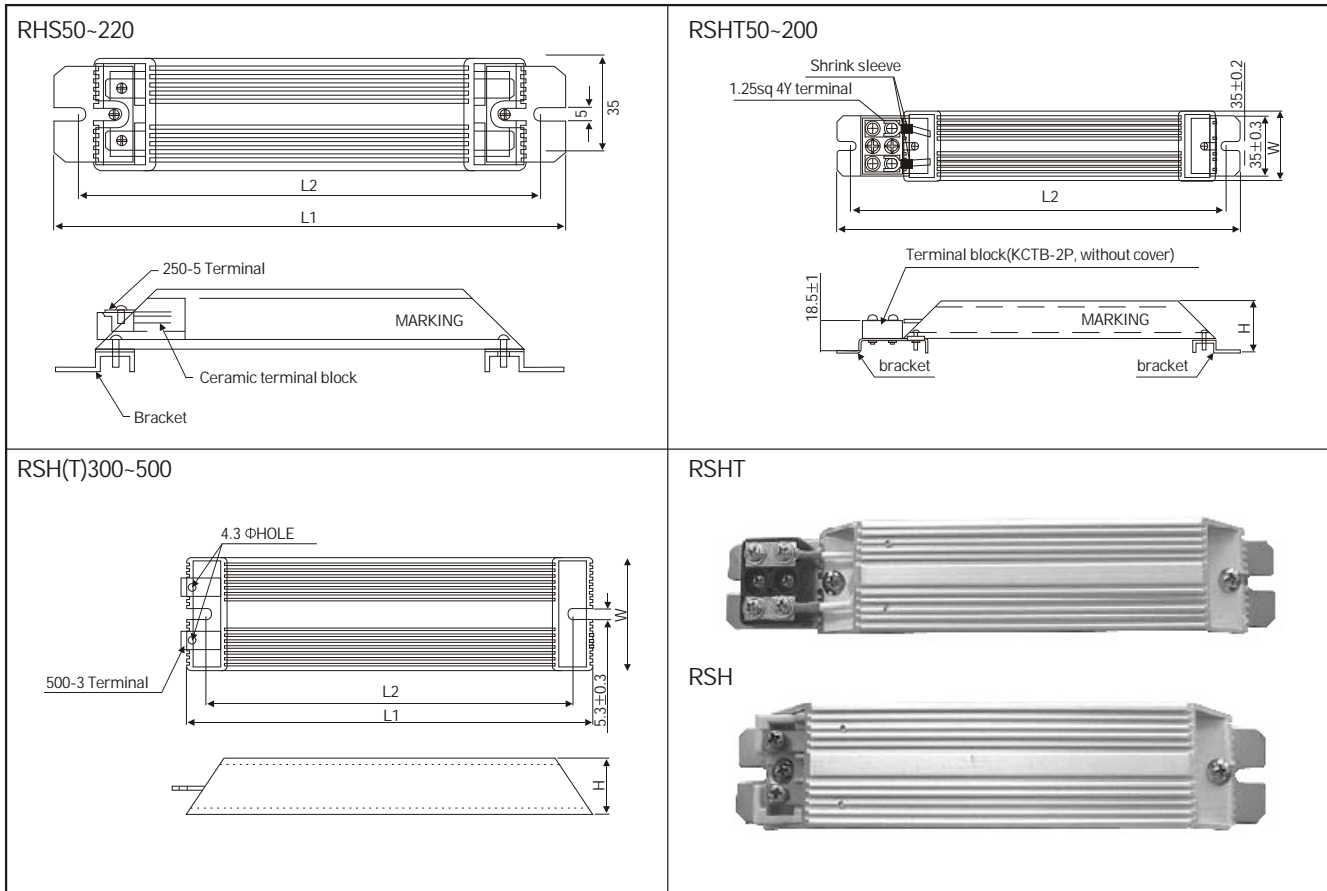

## ■ RSH, RSHT and RSH(T) SPACE HEATERS



## ■ GENERAL SPECIFICATIONS

Model	L1±2	L2±2	W±0.5	H±1	Rated Power[W]	Rated Voltage [V]	Resistance Range [Ω]
RSHT50	151	135	41	30	50	AC 110 - AC 380	$P = \frac{V^2}{R} (+10\%)$
RSH50	127	110	41	30	50		
RSHT60	201	185	41	30	60		
RSH60	177	160	41	30	60		
RSHT80	201	185	41	30	80		
RSH80	177	160	41	30	80		
RSHT100	217	200	41	30	100		
RSH100	192	175	41	30	100		
RSHT120	234	217	41	30	120		
RSH120	209	192	41	30	120		
RSHT150	262	245	41	30	150		
RSH150	237	220	41	30	150		
RSHT200	280	263	41	30	200		
RSH200	255	238	41	30	200		
RSH(T)300	215	196	60	30	300		
RSH(T)400	265	246	60	30	400		
RSH(T)500	335	316	60	30	500		